

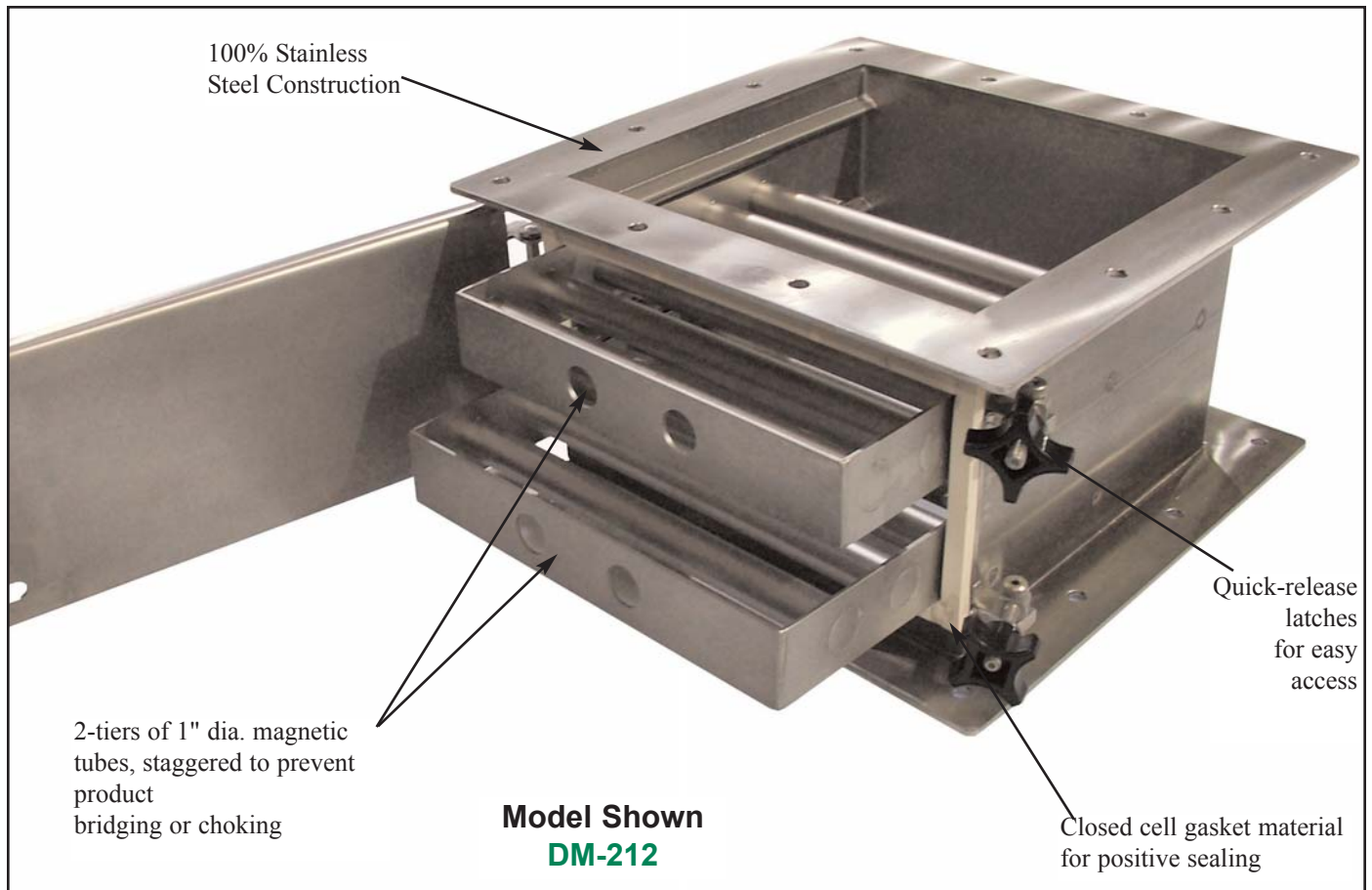

200-Series Drawer Magnet & Housing

Series: DM-200



Application: MPI's Magnetic Drawer and Housings are designed to remove medium and small size ferrous tramp metal contaminants from dry, granular free-flowing product streams in gravity-fed vertical chutes. DM-200 Series Magnetic Drawer and Housings protect processing equipment such as milling, extruding and mixing machinery and at the same time providing higher product quality.

Operation: The product stream flows through two tiers of 1" diameter magnetic tubes designed to create an extremely effective magnetic circuit. The two rows of magnetic tubes are staggered to prevent bridging or choking of the product stream and maximize magnetic filtration as product flows through the housing. Tramp metal contaminants move to the underside of the magnetic tubes, eliminating tramp metal "wash-off". After terminating the product flow, the hinged door can be quickly unlatched and opened to allow quick removal and cleaning of each magnetic drawer.

Got a question about Metal Control
or Material Handling Products...

Ask the
**Magnet
Man**



www.magnetmanusa.com

Magnetic Products, Inc.

Providing Magnetic Solutions for the
Material Handling Industry

800-544-5930



Providing Magnetic Solutions For the Material Handling Industry

For Chute's Maximum Product Flow Opening Area Dimension see Chart Below:

**INLET OPENING AREA
CALCULATIONS:**

For Round Spout: Area = 3.14 x R²
For Square Spout: Area = L x W

DM-Model Number Code:

DM - 224
 └───┬─── 24 INCH PRODUCT OPENING
 └───┬─── 200 SERIES
 └───┬─── DRAWER MAGNET

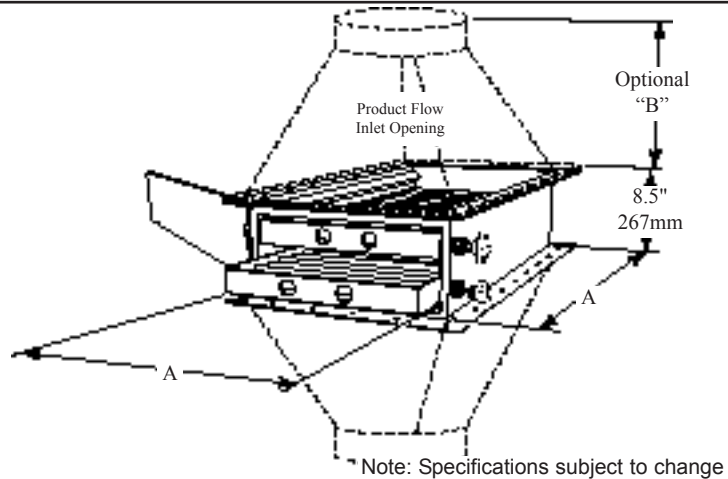

DM-200 SERIES SELECTION GUIDE

DM-200 MODEL NUMBER	CHUTE'S MAX. PRODUCT FLOW OPENING AREA		MAX. MAGNET'S PRODUCT FLOW OPENING AREA "A"		ADAPTER FLANGE HEIGHT OPTIONAL "B"		NUMBER OF MAGNETIC TUBES	APPROX. UNIT'S WEIGHT	
	SQ. IN	SQ. CM	IN.	MM	IN.	MM		LBS.	KG
DM-208	16	103	8	203	4.0	102	7	28	13
DM-210	36	232	10	254	4.0	102	9	35	16
DM-212	64	413	12	305	4.0	102	11	41	19
DM-214	81	523	14	356	4.5	114	13	48	22
DM-216	100	645	16	406	5.0	127	15	54	24
DM-218	144	929	18	457	5.0	127	17	60	27
DM-220	169	1090	20	508	5.5	140	19	67	30
DM-222	196	1265	22	559	6.0	152	21	73	33
DM-224	256	1652	24	610	6.0	152	23	79	36
DM-226	289	1865	26	660	6.5	165	25	86	39
DM-228	324	2090	28	711	7.0	178	27	93	42
DM-230	400	2581	30	762	7.0	178	29	99	45
DM-236	576	3716	36	914	8.0	203	35	120	54

Standard Features:

- Powerful Ceramic 8 permanent magnet material
- 100% Stainless Steel Construction
- Two rows of seam-welded 1" dia. magnetic tubes on 2" centers
- Pre-drilled matching companion flanges, for easy installation

Optional Features:

- Multi-tier configurations
- Non-standard alloy Stainless Steel construction
- Non-standard magnetic tube spacing
- Manual "Quick-Clean" designs
- Automatic "Self-Cleaning" designs

-Custom Sizes & Configurations Available-

For more information, please contact your local sales representative or our customer service representatives at 1-800-544-5930 or info@mpimagnet.com.

Magnetic Products Inc.

P.O. Box 529 • 683 Town Center Dr. • Highland, MI • 48357

TOLL FREE: 800-544-5930 • 248-887-5600

FAX: 248-887-6100

EMAIL: info@mpimagnet.com

www.mpimagnet.com

DISTRIBUTED BY: