

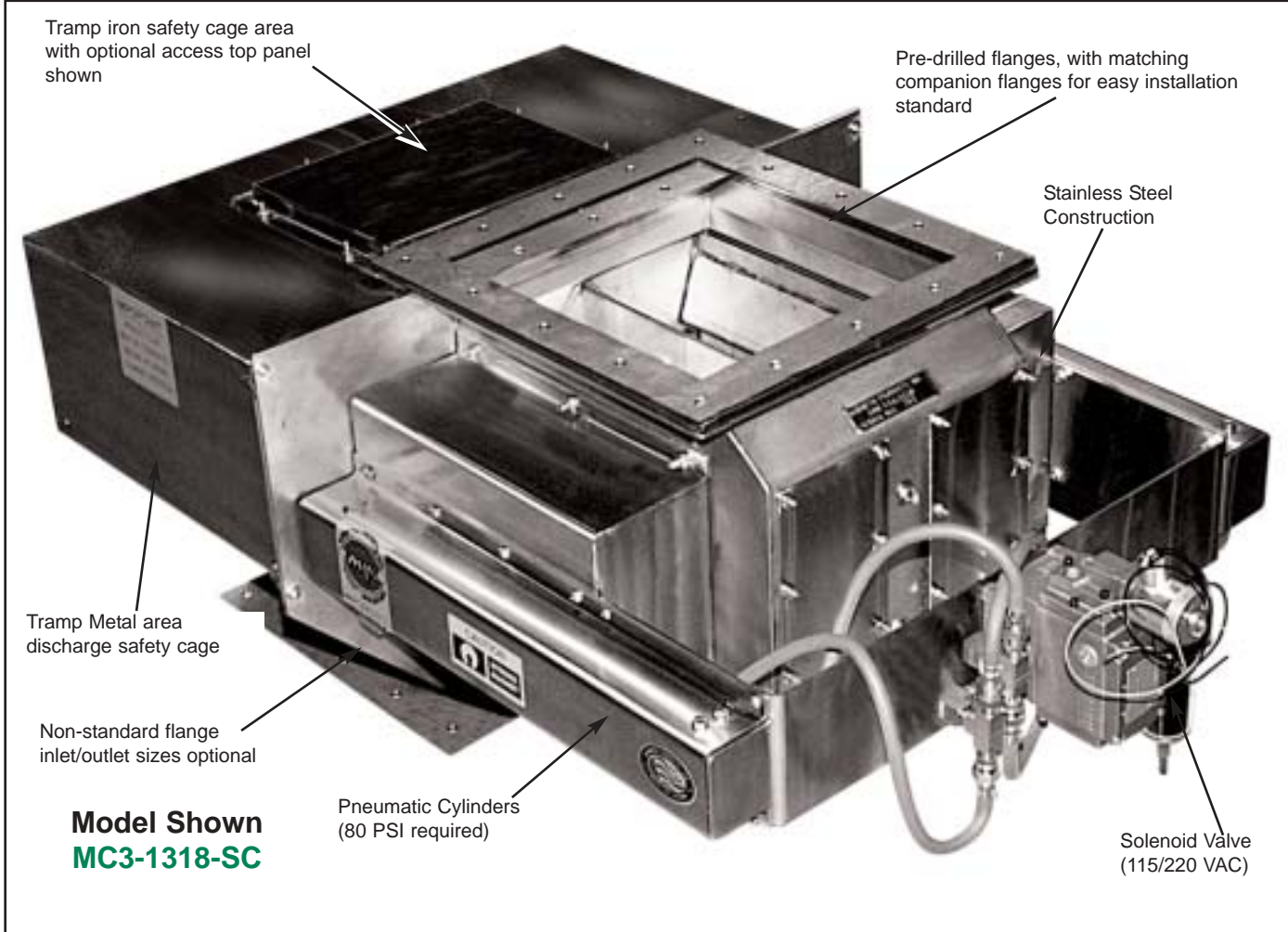

# Three-Cell Magnetic Chute Self-Cleaning Series: MC3-SC



**Application:** MPI's SELF-CLEANING THREE-CELL MAGNETIC CHUTES (MC3-SC Series) are designed to provide improved magnetic filtration with the addition of a 3rd center magnet. This design provides double the magnetic work surface than our (2) cell Magnetic Chute. MC3-SC Series Chute Magnets are designed to capture large, medium, to fine tramp iron in difficult flowing, vertical gravity product streams. For even greater magnetic performance, MC3-SC Series Separators are available with Rare Earth center and/or outer magnetic material elements.

**Operation:** The product flows through two 5" wide chambers, each having opposing powerful (2) pole, (1) face magnetic circuits. As the metal contaminant's are attracted to the magnets, they are drawn to the underside of the step on the magnet's face. This prevents the oncoming product flow from "washing-off" the collected tramp iron from the magnets between cleaning cycles. A self-cleaning liner is provided to remove the metal contaminant's from the magnets. Simply terminate the product flow and the pneumatically operated cleaning shell safely removes tramp metal from the product stream to a disposal area outside the product flow area.

Got a question about Metal Control or Material Handling Products...  
**Ask the Magnet Man**

[www.magnetmanusa.com](http://www.magnetmanusa.com)

## Magnetic Products, Inc.

Providing Magnetic Solutions for the Material Handling Industry

**800-544-5930**



# Providing Magnetic Solutions For the Material Handling Industry

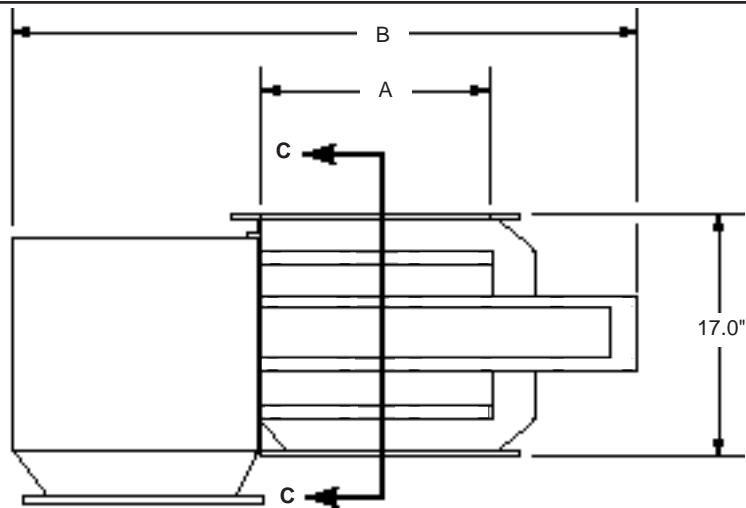
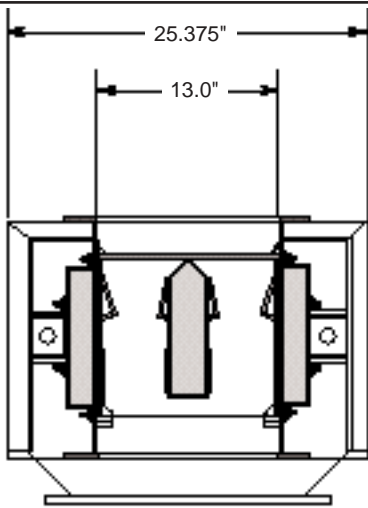

## MC3-SC SELECTION CHART

MC3-SC MODEL NUMBERS	PRODUCT FLOW CAPACITIES *		PRODUCT FLOW OPENING LENGTH "A"		OVERALL LENGTH "B"		APPROX. UNIT'S WEIGHT	
	CU/FT/HR	BU/HR	IN.	CM	IN.	CM	LBS.	KG
	MC3-1310-SC	2,200	1,760	10	25.4	40.1	101.8	245
MC3-1312-SC	2,500	2,000	12	30.4	44.1	112.0	288	130.7
MC3-1314-SC	3,000	2,400	14	35.5	48.1	122.1	331	150.2
MC3-1316-SC	3,500	2,800	16	40.6	52.1	132.3	374	169.7
MC3-1318-SC	4,000	3,200	18	45.7	56.1	142.4	417	189.3
MC3-1320-SC	5,000	4,000	20	50.8	60.1	152.6	460	208.8
MC3-1322-SC	6,000	4,800	22	55.8	64.1	162.8	503	228.3
MC3-1324-SC	7,020	5,616	24	60.9	68.1	172.9	546	247.8
MC3-1326-SC	8,500	6,800	26	66.0	72.1	183.1	589	267.4
MC3-1328-SC	10,000	8,000	28	71.1	76.1	193.2	632	286.9
MC3-1330-SC	11,500	9,200	30	76.2	80.1	203.4	675	306.4
MC3-1332-SC	13,300	10,640	32	81.2	84.1	213.6	718	325.4
MC3-1334-SC	15,200	12,160	34	86.3	88.1	223.7	761	345.4
MC3-1336-SC	17,000	13,600	36	91.4	92.1	233.9	804	365.0

\* CAPACITIES ARE BASED ON DRY, GRANULAR PRODUCTS WITH A BULK DENSITY OF APPROX. 50 LBS. PER CUBIC FT.

SPECIFICATIONS SUBJECT TO CHANGE. SPECIAL SIZES AVAILABLE UPON REQUEST

### Standard Features:

- Powerful Ceramic Magnet Material
- Stainless Steel Construction
- Closed Cell Gasket Material for positive sealing
- Center magnet and outer magnets are single stepped for maximum tramp iron removal

### Optional Features:

- High-Energy Rare Earth magnet material
- Non-standard alloy Stainless Steel construction
- Tramp Iron Collection Trays
- Chute Transition Adapters

## Magnetic Products Inc.

P.O. Box 529 • 683 Town Center Dr. • Highland, MI • 48357

TOLL FREE: 800-544-5930 • 248-887-5600

FAX: 248-887-6100

EMAIL: [info@mpimagnet.com](mailto:info@mpimagnet.com)

[www.mpimagnet.com](http://www.mpimagnet.com)

DISTRIBUTED BY: